

THE CORPORATION OF THE CITY OF NORTH BAY

BY-LAW NO. 179-81

BEING A BY-LAW TO AMEND BY-LAW NO. 28-80,
CONSOLIDATED ZONING BY-LAW OF THE CITY OF
NORTH BAY

WHEREAS the City of North Bay Restricted Area Zoning By-Law No. 28-80 has been duly passed and circulated to replace the 3 Restricted Area Zoning By-Laws now in force and effect in the City of North Bay, being By-Law No. 9-69 of the City of North Bay, By-Law No. 907 of the former Township of West Ferris and By-Law No. 1097 of the former Township of Widdifield.

AND WHEREAS 9 amendments were made to the Restricted Area Zoning By-Laws in force and effect in the City being By-Laws No. 1-80, 15-80, 24-80, 36-80, 37-80, 38-80, 46-80, 103-80 and 122-80; which amendments were circulated without objection and came into force and effect pursuant to Ontario Regulation 78/80; but which amendments were not incorporated in By-Law 28-80 or any amendments thereto.

AND WHEREAS the Council of the City of North Bay deems it desirable to amend Zoning By-Law No. 28-80 to incorporate the said 9 amendments and to request the Ontario Municipal Board to approve the said 9 amendments to By-Law No. 28-80 without further notice or hearing.

NOW, THEREFORE, THE COUNCIL OF THE CORPORATION OF THE CITY OF NORTH BAY HEREBY ENACTS AS FOLLOWS:

1. (a) Schedule "B-33" to By-Law No. 28-80 is amended by deleting the Residential Second Density "R.2" Zone shown in a shaded manner on Schedule "A" to this By-Law and inserting therefor the Residential Third Density "R.3" Zone.
(b) By-Law No. 122-80 is hereby repealed.
2. (a) Schedule "B-34" to By-Law No. 28-80 is amended by deleting the Residential Holding "RH" Zone shown in a shaded manner on Schedule "B" to this By-Law and inserting therefor the Residential First Density "R.1" Zone.
(b) By-Law No. 24-80 is hereby repealed.
3. (a) Schedule "B-44" to By-Law No. 28-80 is amended by deleting the Residential First Density "R.1" Zone shown in a shaded manner on Schedule "C" to this By-Law and inserting therefor the Residential Second Density "R.2" Zone.
(b) By-Law No. 1-80 is hereby repealed.
4. (a) Schedule "B-45" to By-Law No. 28-80 is amended by deleting the Residential First Density "R.1" Zone shown in a shaded manner on Schedule "D" to this By-Law and inserting therefor the Residential Second Density "R.2" Zone.
(b) By-Law No. 37-80 is hereby repealed.
5. (a) Schedule "B-50" to By-Law No. 28-80 is amended by deleting the Residential Multiple First Density "RM.1" Zone shown in a shaded manner on Schedule "E" to this By-Law and inserting therefor the General Commercial Outer Core "C.2" Zone.
(b) Sections 1, 3, 4 and 5 of By-Law No. 36-80 are hereby repealed.

6. (a) Schedule "B-50" to By-Law No. 28-80 as amended is further amended by deleting the Residential Multiple First Density "RM.1" Zone shown in a shaded manner on Schedule "E" to this By-Law and inserting therefor the General Commercial Outer Core "C.2" Zone.
(b) By-Law No. 46-80 is hereby repealed.
7. (a) Schedule "B-51" to By-Law No. 28-80 is amended by deleting the Residential Third Density "R.3" Zone and the Light Industrial Class #2 "M.2" Zone shown in a shaded manner on Schedule "F" to this By-Law and inserting therefor the Industrial Special 11 "MSP.11" Zone.
(b) By-Law No. 15-80 is hereby repealed.
8. Schedule "B-52" to By-Law No. 28-80 is amended by deleting the Light Industrial Class #2 "M.2" Zone shown in a shaded manner on Schedule "G" to this By-Law and inserting therefor the Industrial Special 11 "MSP.11" Zone.
9. (a) Schedule "B-52" to By-Law No. 28-80 as amended is further amended by deleting the Light Industrial Class #2 "M.2" Zone shown in a shaded manner on Schedule "G" to this By-Law and inserting the Industrial Special 12 "MSP.12" Zone.
(b) By-Law No. 38-80 is hereby repealed.
10. (a) Schedule "C-10" to By-Law No. 28-80 is amended by deleting the Rural "A" Zone shown in a shaded manner on Schedule "H" to this By-Law and inserting the Industrial Special 13 "MSP.13" Zone.
(b) By-Law No. 103-80 is hereby repealed.
11. Section 11 of By-Law No. 28-80 is amended by inserting a new section 11.4.11 as follows:
"11.4.11 Industrial Special Zone 11 (MSP.11)
11.4.11.1 The property description of this Industrial Special 11 Zone is:
Plan No. 75 Lots 68, 69 and 70
and Plan 36R-5463 Part 1 as
shown on the attached Site Plan
and Schedules "B-51" and "B-52"
11.4.11.2 The special requirements for this Industrial Special 11 Zone are as follows:
(a) The Permitted Uses in this Zone are:
Clubs and Fraternal Organizations
Accessory Uses to the above
(b) The regulations for this zone are:
(i) The maximum lot coverage shall be twenty (20) percent.
(ii) The setback from the front lot line shall be a minimum of seven and six-tenths (7.6) metres.

- (iii) The setback from the side lot line shall be a minimum of one and two-tenths (1.2) metres.
- (iv) The setback from the rear lot line shall be a minimum on one and eight-tenths (1.8) metres.
- (v) The parking requirements shall be one (1) parking space for every five (5) seats or three (3) metres of bench space of its maximum seating capacity; where there are no fixed seats, one (1) parking space for each nine (9) square metres of floor area devoted to public use.

11.4.11.3 The use of land in this Industrial Special 11 Zone shall conform to all other regulations of this By-Law, except as hereby expressly varied."

12. Section 11 of By-Law No. 28-80 as amended is further amended by inserting a new section 11.4.12 as follows:

"11.4.12 Industrial Special Zone 12 (MSP.12)

11.4.12.1 The property description of this Industrial Special 12 Zone is:

Part 6 of Plan NR 1441 as shown on the attached Site Plan and Schedule "B-52"

11.4.12.2 The special requirements for this Industrial Special 12 Zone are as follows:

(a) The Permitted Uses in this Zone are:

Furniture sales showroom and warehouse
Accessory Uses to the above

(b) The regulations for this Zone are:

(i) The setback from the front lot line shall be a minimum of four and five tenths (4.5) metres.

(ii) The setback from the northeast side lot line, being the common property boundary to the North Bay By-Pass (MTC Plan P-2785-175) shall be a minimum of twenty-four (24) metres.
The setback from the southwest side lot line may be nil.

(iii) The setback from the rear lot line shall be a minimum of one and two tenths (1.2) metres.

11.4.12.3 The use of land in this Industrial Special 12 Zone shall conform to all other regulations of this By-Law, except as hereby expressly varied."

13. Section 11 of By-Law No. 28-80 as amended is further amended by inserting a new section 11.4.13 as follows:

"11.4.13 Industrial Special Zone 13 (MSP.13)

11.4.13.1 The property description of this Industrial Special 13 Zone is:

Part of Parcel 5690 W & F as shown on the attached site plan and Schedule "C-10".

11.4.13.2 The special requirements for this Industrial Special 13 Zone are as follows:

(a) The Permitted Uses in this Zone are:

Truck Sales and Service
Accessory Uses to the Above

(b) The regulations for this Zone are:

(i) The minimum lot area shall be eight tenths (.8) Hectares;

(ii) The minimum lot frontage shall be seventy-six (76) metres;

(iii) The minimum front yard setback shall be fifteen (15) metres;

(iv) The minimum side yard setback shall be fifteen (15) metres;

(v) The minimum rear yard setback shall be fifteen (15) metres;

(vi) The maximum lot coverage shall be fifteen (15) percent;

11.4.13.3 The use of land in this Industrial Special 13 Zone shall conform to all other regulations of this By-law except as hereby expressly varied.

14. Section 11 of By-Law No. 28-80 as amended is further amended by inserting "Schedule to Industrial Special Zone No. 11 (MSP.11)" as shown on Schedule "I" to this By-law.

15. Section 11 of By-Law No. 28-80 as amended is further amended by inserting "Schedule to Industrial Special Zone No. 12 (MSP.12)" as shown on Schedule "J" to this By-Law.

16. Section 11 of By-Law No. 28-80 as amended is further amended by inserting "Schedule to Industrial Special Zone No. 13 (MSP.13)" as shown on Schedule "K" to this By-Law.
17. This By-Law takes effect from the date of passage by Council and comes into force upon approval by the Ontario Municipal Board.

READ A FIRST TIME IN OPEN COUNCIL THE 30th DAY OF November, 1981.
READ A SECOND TIME IN OPEN COUNCIL THE 14th DAY OF December, 1981.
READ A THIRD TIME IN OPEN COUNCIL AND ENACTED AND PASSED THIS 14th
DAY OF DECEMBER, 1981.



MAYOR



CITY CLERK

This is Schedule "A"

To By-Law No. 179-81

Passed the 14th day of December, 1981.



Mayor



City Clerk

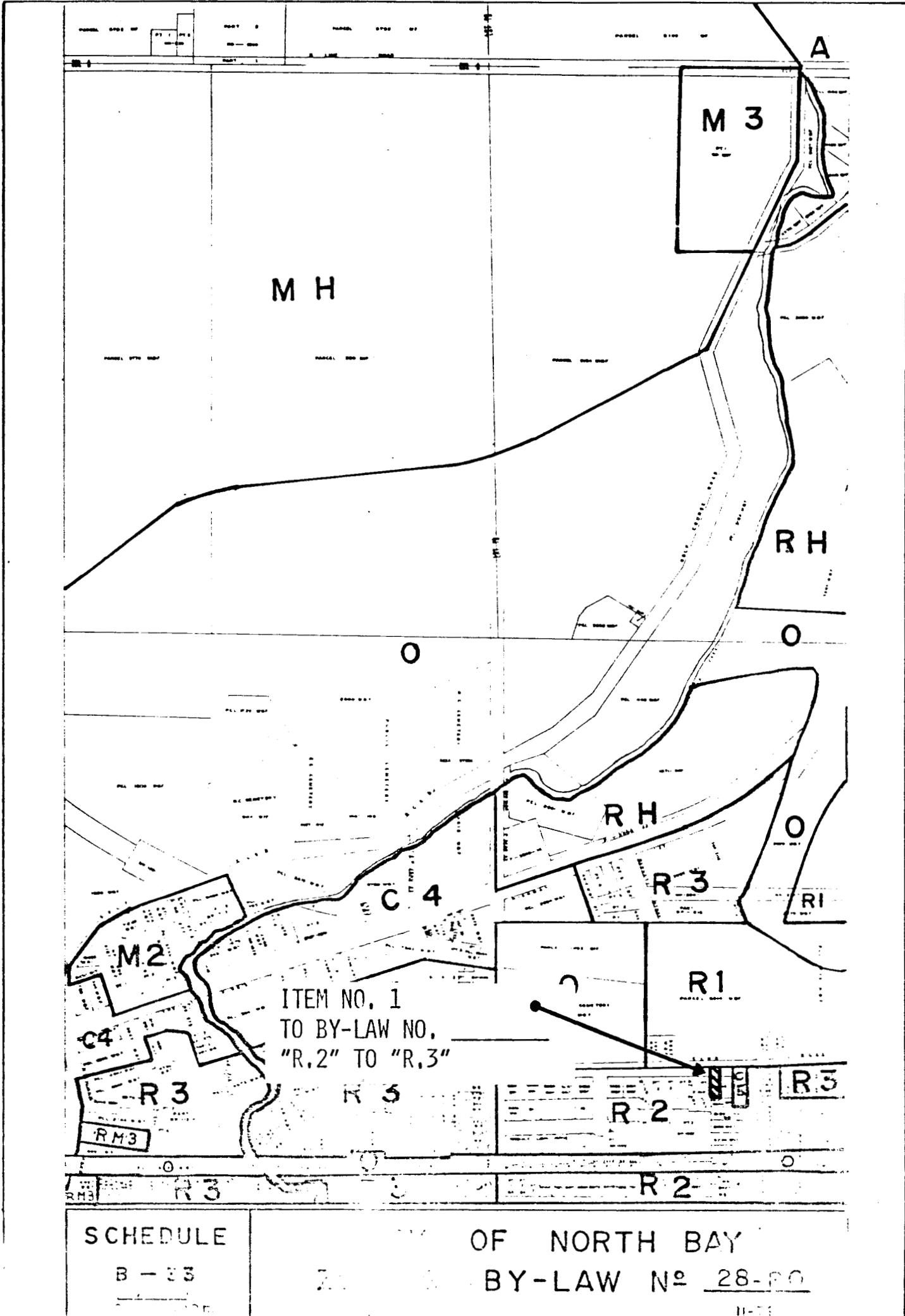

This is Schedule "B".

To By-Law No. 179-81

Passed the 14th day of December, 1981

[Signature]
Mayor

[Signature]
City Clerk

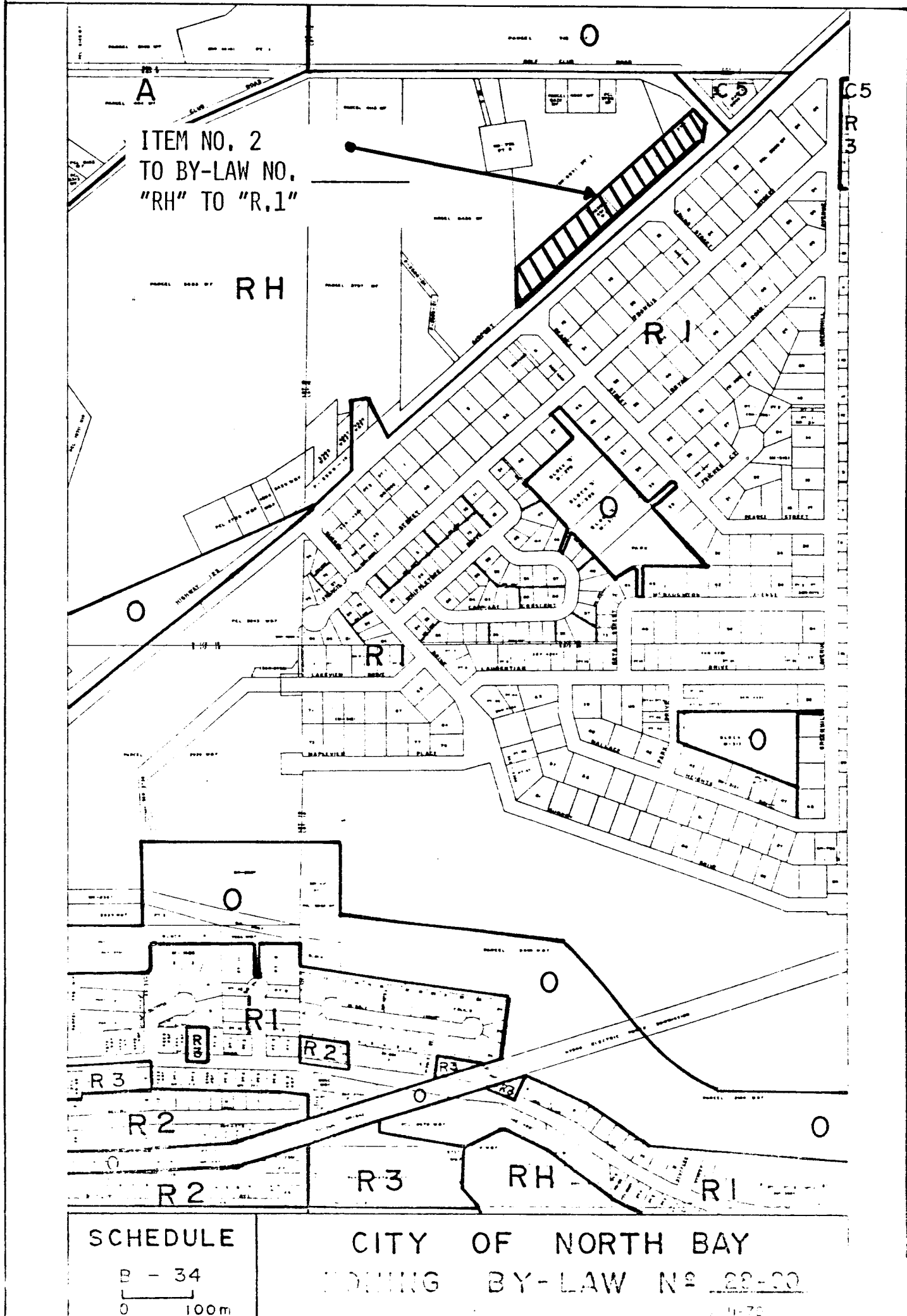

This is Schedule "C"

To By-Law No. 179-81

Passed the 14th day of December, 1981.

Mayor

City Clerk

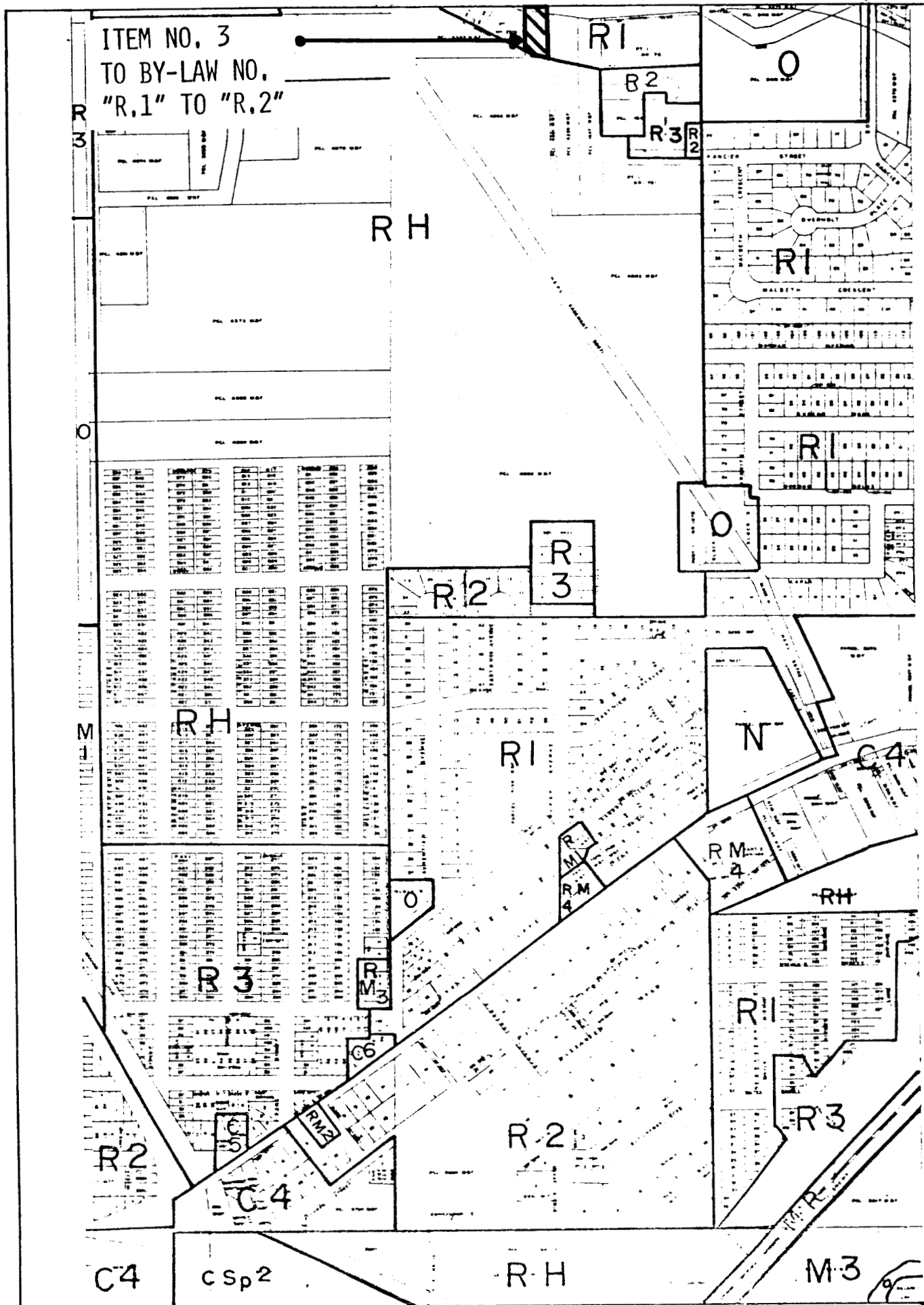

<p>SCHEDULE 3 - 44 0 - 100m</p>	<p>CITY OF NORTH BAY ZONING BY-LAW 28-80 11-79</p>
---	--

This is Schedule "D"

To By-Law No. 179-81

Passed the 14th day of December, 1981.

[Signature]
Mayor

[Signature]
City Clerk

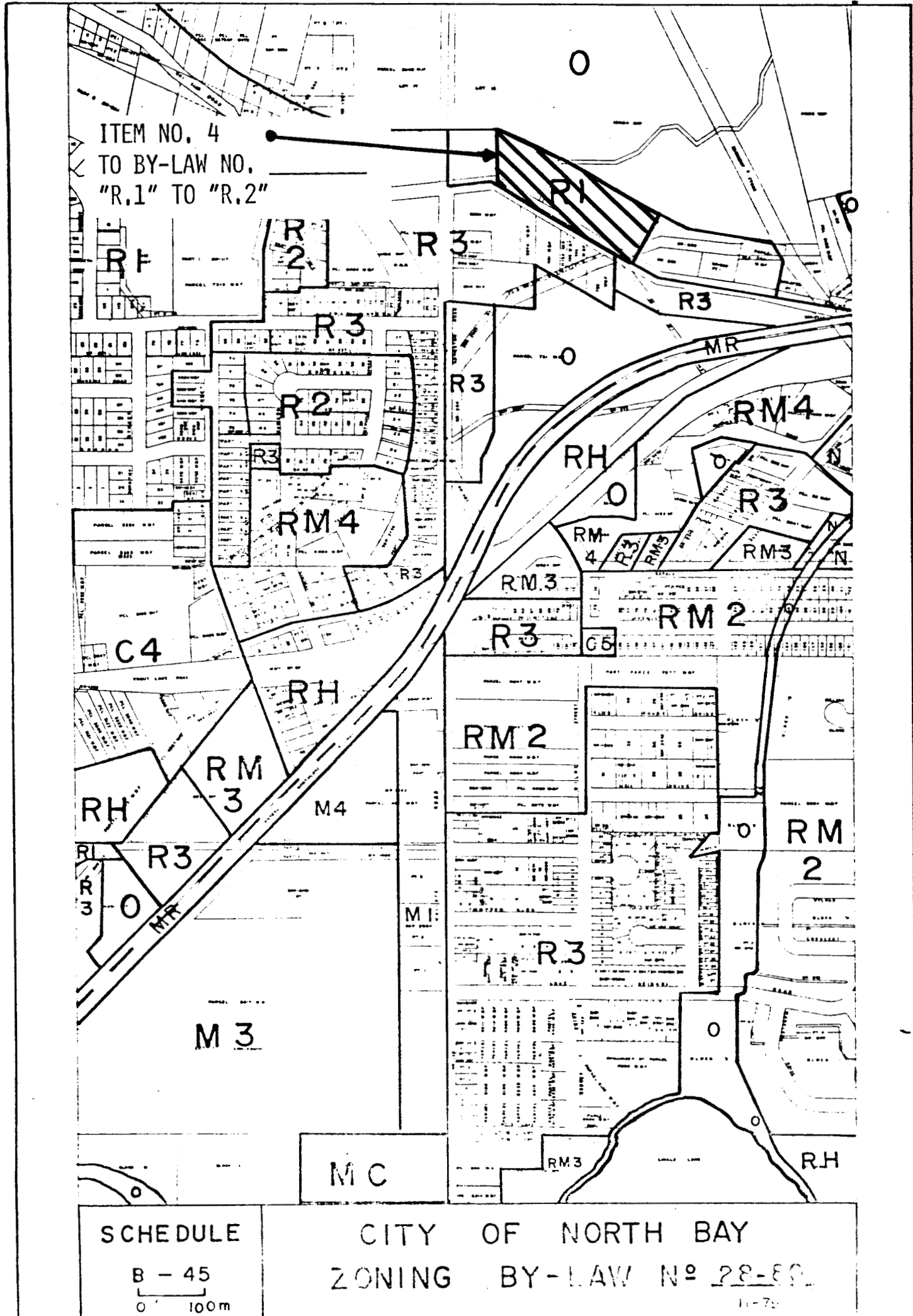

This is Schedule "E"

To By-Law NO. 179-81

Passed the 14th day of December, 1981.

[Signature]
Mayor

[Signature]
City Clerk

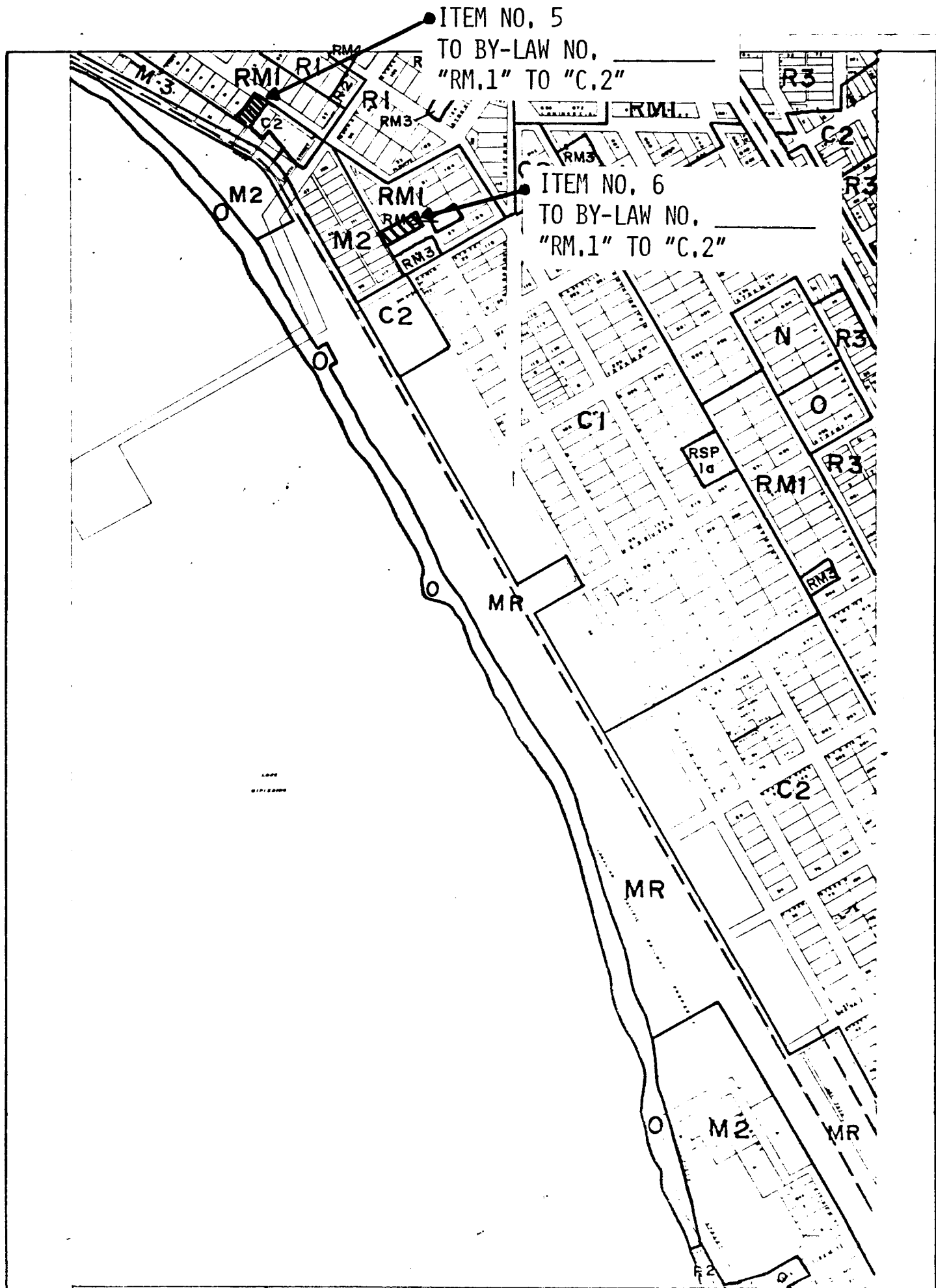

<p>DATE</p> <p>BY</p> <p>APPROVED</p>	<p>CITY OF NORTH BAY</p> <p>ZONING BY-LAW NO. 28-80</p> <p>11-75</p>
---------------------------------------	--

This is Schedule "F"

To By-Law No. 179-81

Passed the 14th day of December, 1981

[Signature]
Mayor

[Signature]
City Clerk

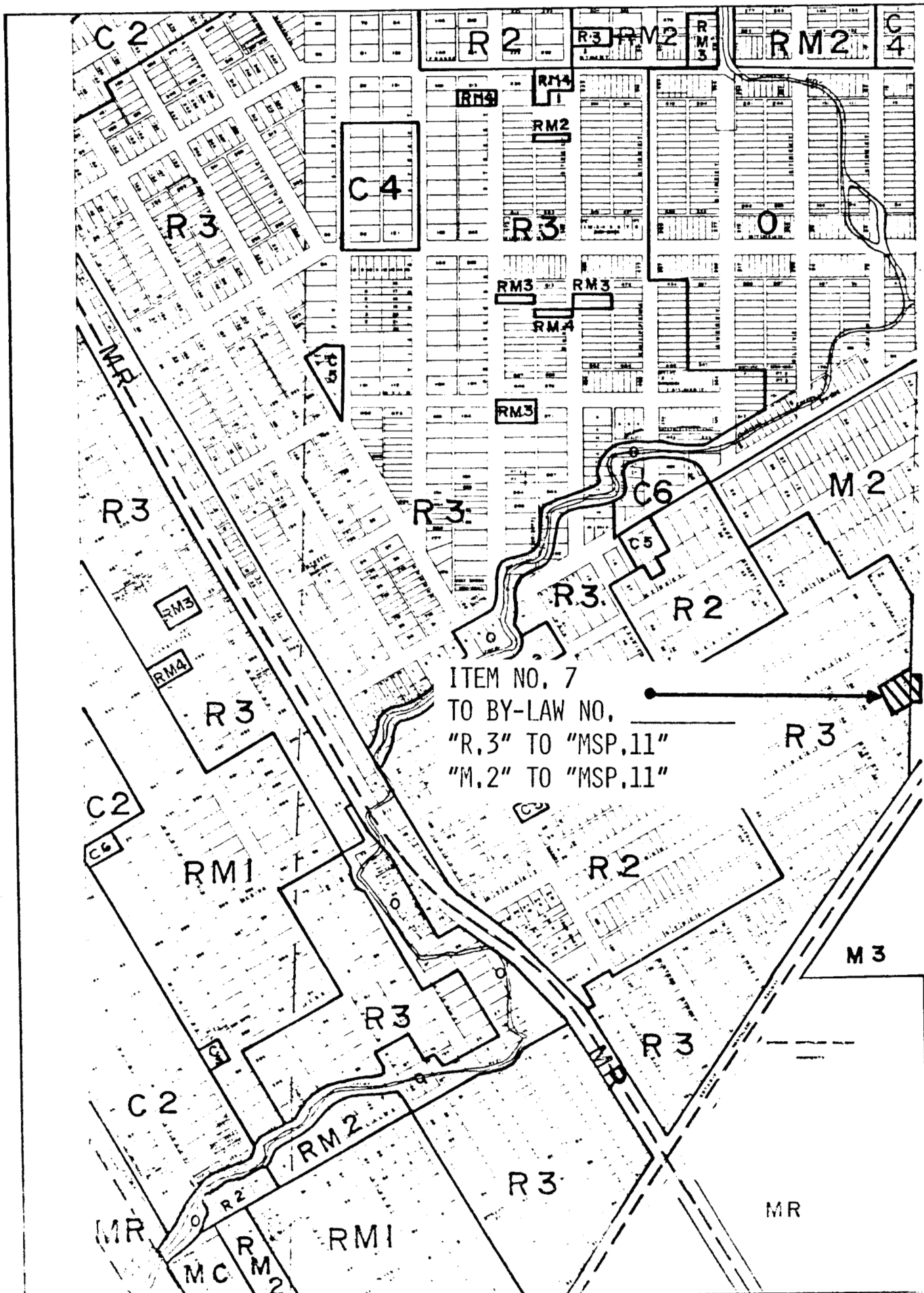

SCHEDULE

B - 51
0 100m

CITY OF NORTH BAY
ZONING BY-LAW NO. 28-82

This is Schedule "G"

To By-Law No. 179-81

Passed the 14th day of December, 1981.

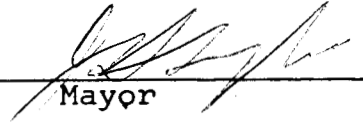
Mayor

City Clerk

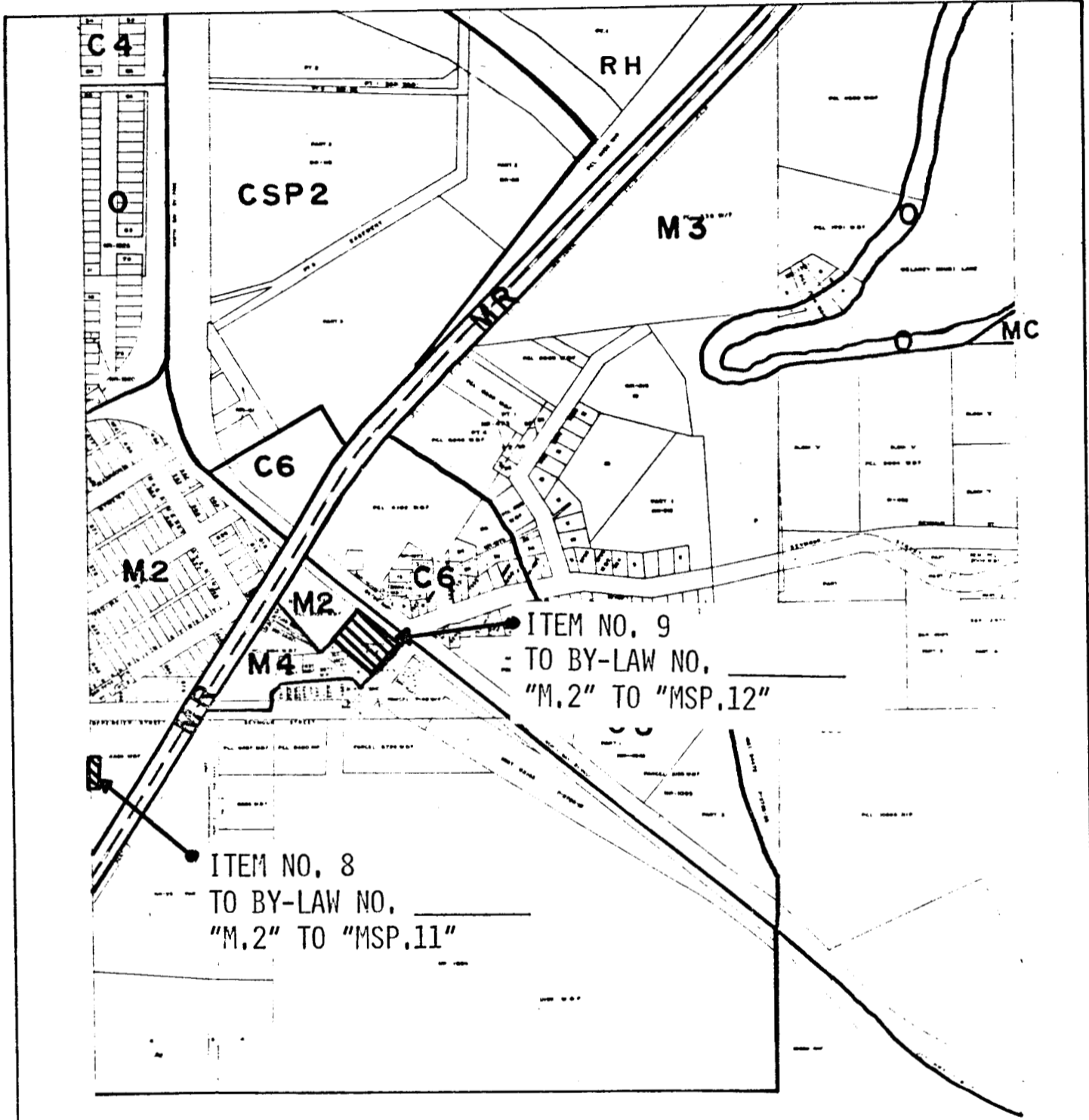

This is Schedule "H"

To By-Law No. 179-81

Passed the 14th day of December, 1981.

Mayor

City Clerk

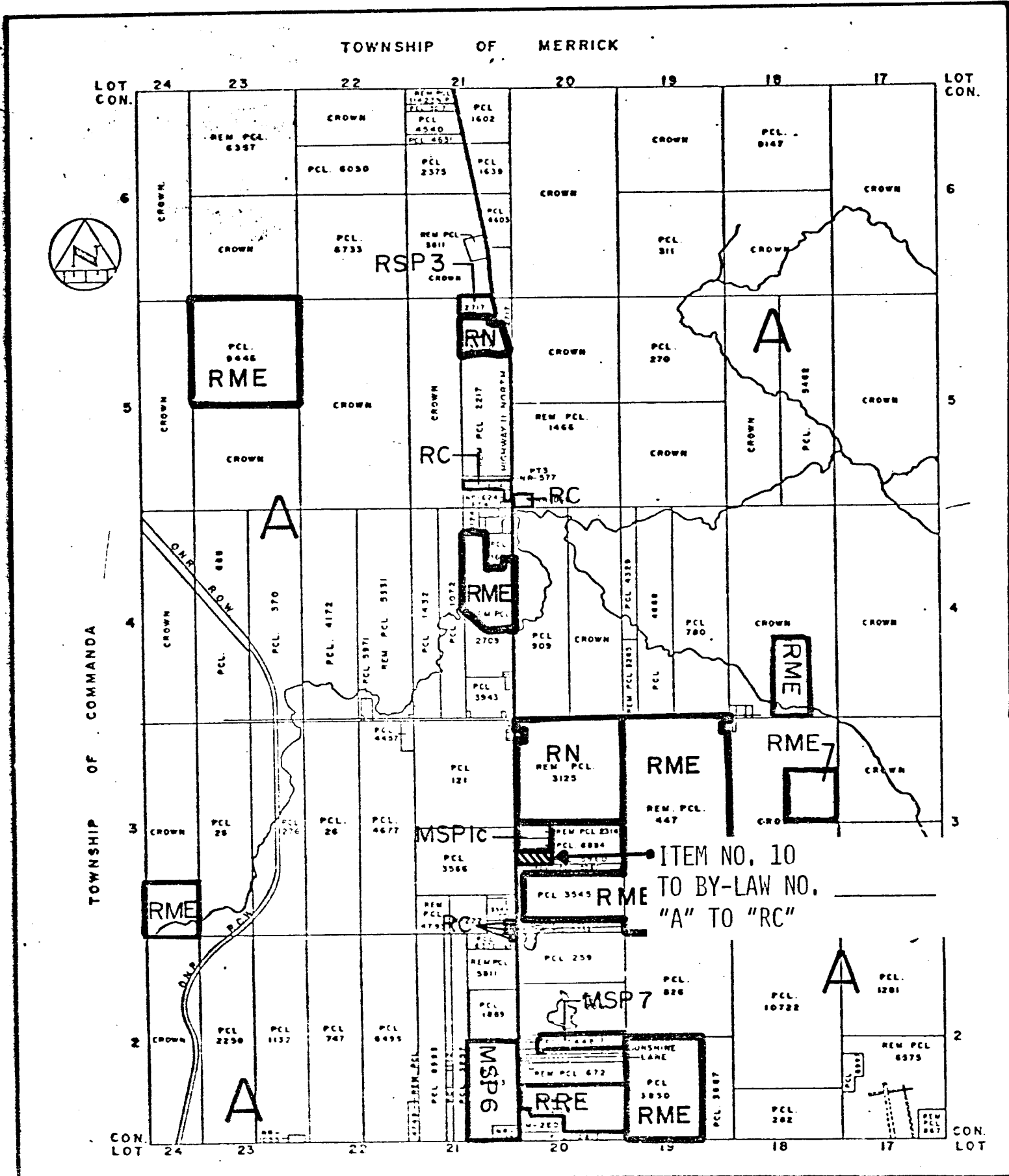

SCHEDULE

C10

CITY OF NORTH BAY
ZONING BY-LAW NO. 28-110

This is Schedule "I"

To By-Law No. 179-81

Passed the 14th day of December, 1981.



Mayor



City Clerk

SCHEDULE TO INDUSTRIAL SPECIAL ZONE 11(MSP.11)

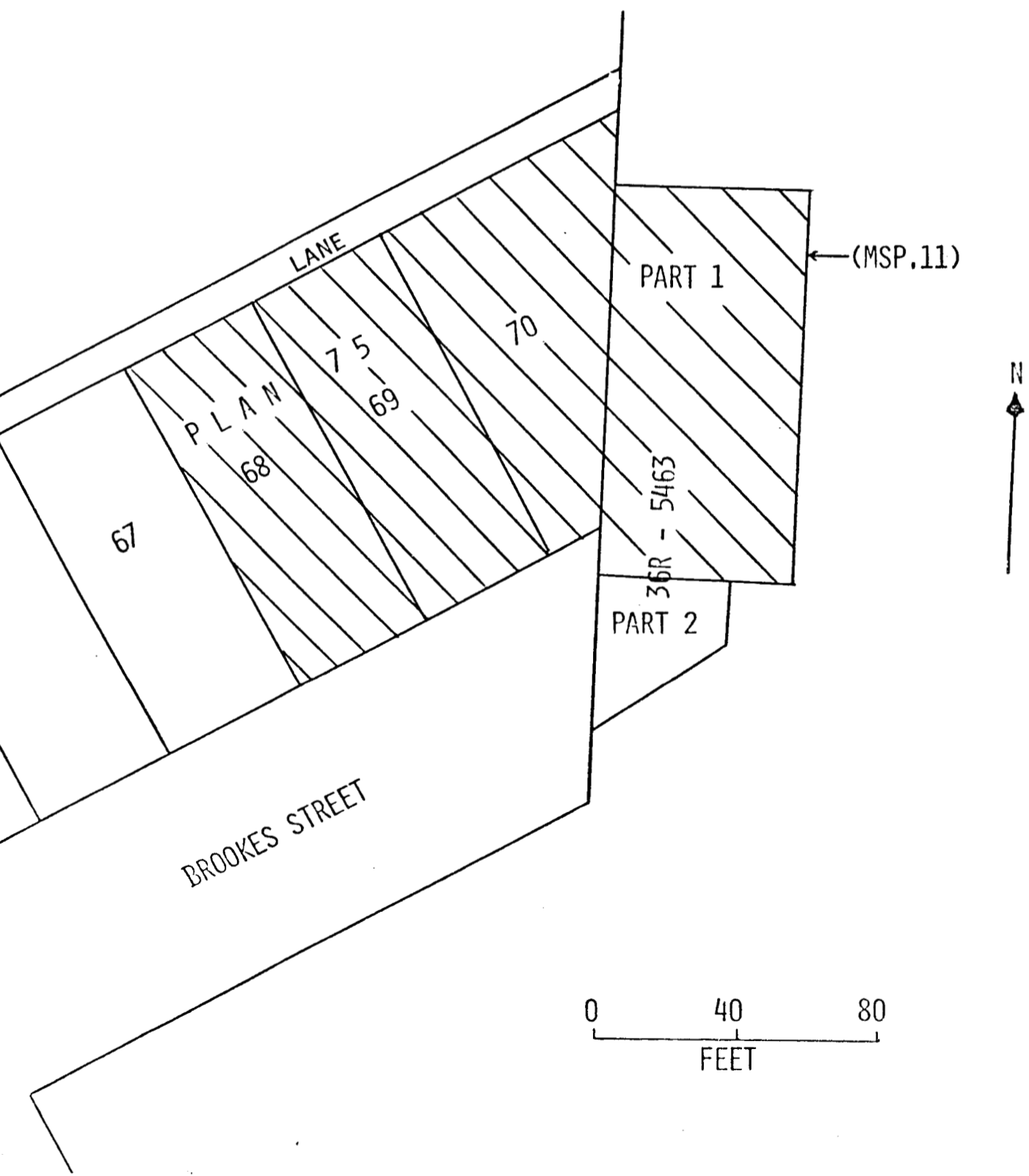

This is Schedule "J"

To By-Law No. 179-81

Passed the 14th day of December, 1981

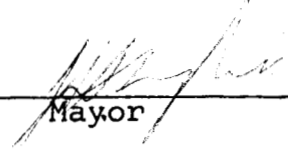

Mayor

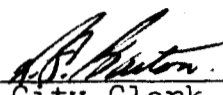

City Clerk

SCHEDULE TO INDUSTRIAL SPECIAL ZONE 12 (MSP.12)

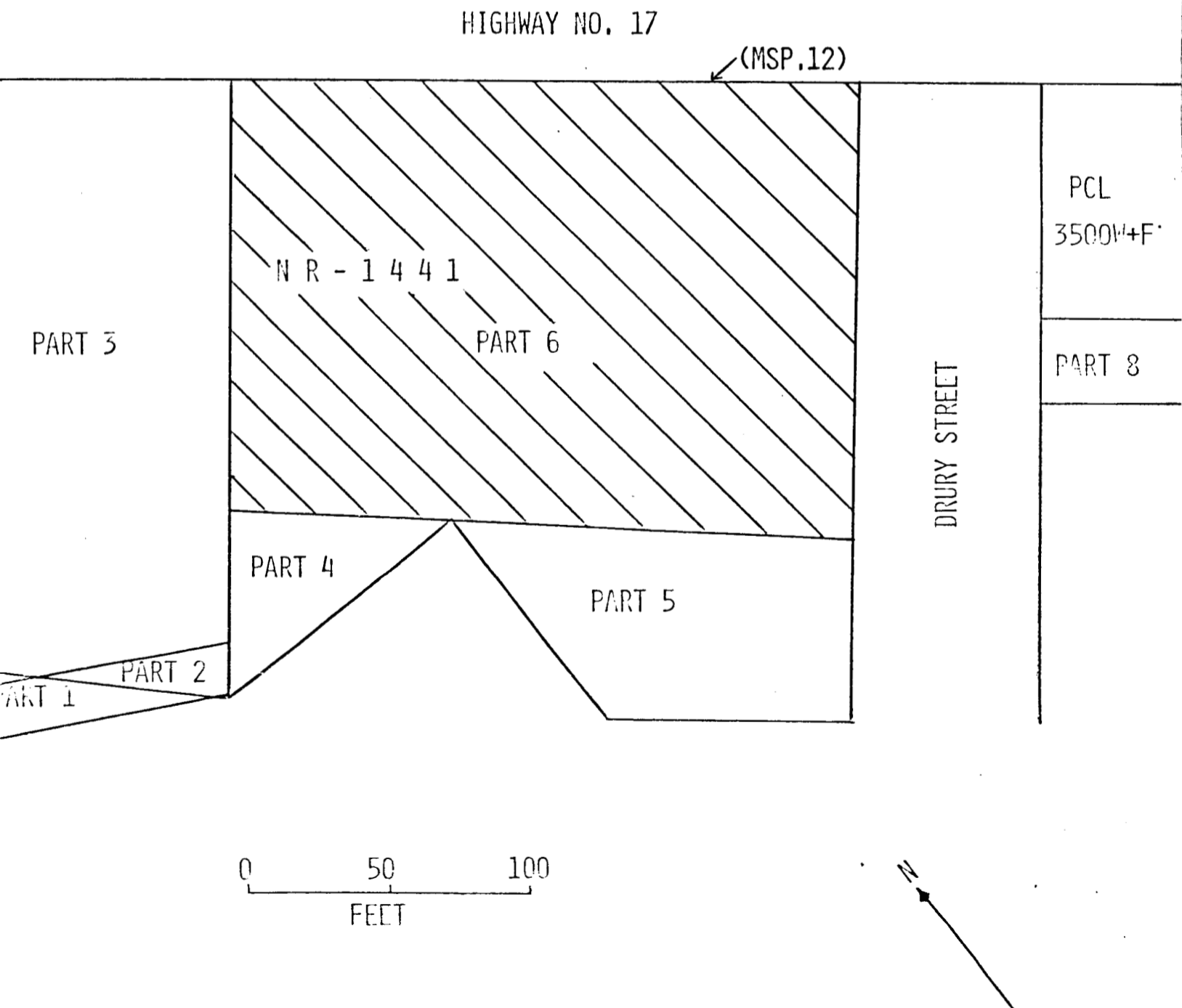

This is Schedule "K"

To By-Law No. 179-81

Passed the 14th day of December, 1981.



Mayor



City Clerk

SCHEDULE TO INDUSTRIAL SPECIAL ZONE 13(MSP.13)

